

# LeakStopGun

## Operating Manual



©Leak Stop Gun LP

Version: 2023.09.1

## Manual Content

<b>1. Preface</b>	<b>3</b>
1.1 Introduction	3
1.2 Copyrights and Property Rights	3
1.3 Information for the Operator	3
<b>2. Safety</b>	<b>4</b>
2.1 Notes on Signs and Symbols	4
2.2 Intended Use of Product	5
2.3 Reasonably foreseeable misuse	5
2.4 Residual Risk	6
2.5 Description of Protective Devices	6
2.6 Markings and Signs on LSG	7
2.7 Operating Personnel	7
2.8 Safety Instructions for Operating Personnel	7
2.9 Safety Instructions for Maintenance Personnel	8
2.9.1 Preparation of Maintenance Work	8
2.9.2 Carrying out the maintenance work	8
2.10 Notes on Special Types of Dangers	8
2.10.1 Raw Materials, Solvents, Oils, Fats, and other chemical substances	8
2.10.2 Noise	9
<b>3. Product Description</b>	<b>10</b>
3.1 Functional Description	11
3.2 Assemblies of LSG	11
3.3 Classification according to the Pressure Equipment Directive	12
<b>4. Transportation and Assembly</b>	<b>14</b>
<b>5. Operation</b>	<b>14</b>
5.1 Safe Operation	14
5.2 Controls	15
5.3 Installation	15
5.4 Operation	16
5.5 Errors	21

<b>6. Maintenance</b>	<b>22</b>
<b>6.1 Care/Cleaning</b>	<b>23</b>
<b>6.2 Maintenance</b>	<b>24</b>
6.2.1 General Maintenance Instructions	24
6.2.2 Preparation of Repair and Maintenance Work	24
<b>6.3 Maintenance Schedule</b>	<b>25</b>
6.3.1 Changing the Pressure Tank	26
<b>6.4 Repair</b>	<b>26</b>
<b>7. Disposal</b>	<b>26</b>
<b>7.1 Environmental Protection</b>	<b>26</b>
<b>7.2 Oil and Waste Containing Oil, Lubricating Greases</b>	<b>27</b>
<b>7.3 Plastics</b>	<b>27</b>
<b>7.4 Metals</b>	<b>27</b>
<b>7.5 Scrapping</b>	<b>27</b>
<b>Appendix</b>	<b>28</b>
<b>A.1 Declaration of Conformity</b>	<b>28</b>
<b>A.2 Assembly Drawings</b>	<b>28</b>
<b>A.3 Parts list with spare parts recommendation/identification</b>	<b>29</b>

## 1. Preface

### 1.1 Introduction

Throughout this manual the LeakStopGun, as a tool, will be further referred to as LSG.

The operating manual contains important information on how to operate the LSG safely, properly and economically. Observing them avoids hazards, reduces repair costs and downtime and increases the reliability and service life of the LSG.

The operating manual must be always available and must be read and used by every person who carries out work on or with the LSG.

These include, among other things.

- a. the operation and elimination of malfunctions in operation
- b. maintenance (care, maintenance, repair)
- c. the transport

### 1.2 Copyrights and Property Rights

Only make these operating instructions accessible to authorized persons.

The operating instructions are protected under copyright law.

The passing on and duplication of documents, including excerpts, as well as the utilization and communication of their content are not permitted unless this is expressly permitted in writing.

Violations are punishable and oblige to compensation. LEAK STOP GUN LP reserves all rights to exercise industrial property rights.

### 1.3 Information for the Operator

The operating manual is an essential part of the LSG.

Ensure that all persons who work with or on the LSG take note of these operating instructions.

Spare parts must meet the technical requirements specified by LEAK STOP GUN LP. This is always guaranteed with original spare parts.

## 2. Safety

The LSG has been developed and built according to the state of the art and the recognized safety regulations.

When operating the LSG, there may be dangers for people working on or with the LSG or damage to the LSG and other property if they:

- operated by untrained or instructed personnel,
- used improperly and/or
- is improperly maintained.

### 2.1 Notes on Signs and Symbols

The following terms, signs and symbols are used in the operating instructions for particularly important information:

Work and/or operating steps are marked with the focal point. Follow the steps in order. Enumerations are marked with dashes.



This is a warning of an imminently hazardous situation which will inevitably result in serious injury or death if the indicated instruction is not followed exactly.



Draws attention to a potentially hazardous situation that could result in serious personal injury or death if the indicated instruction is not followed exactly.



This is a warning of a potentially hazardous situation that may result in moderate or minor injury if the specified instruction is not followed exactly.

# NOTICE

This is a warning of a potentially hazardous situation that could result in property damage if the specified instruction is not followed exactly.

This is a reference to useful information on safe and proper handling.

Observe the warning labels, actuating labels or component markings attached to the LSG. They may not be removed.

Always keep these notices and symbols in a legible condition.

## 2.2 Intended Use of Product

The LSG is used to quickly seal unwanted leaks.

The LSG can also be used in potentially explosive atmospheres because it does not have an ignition source itself.

Intended use also includes compliance with the instructions.

- for safety,
- for operation and control,
- for maintenance and servicing

which are described in this operating manual.

Any other use or use that goes beyond this is deemed to be improper. The operator alone is liable for any resulting damage. This also applies to unauthorized changes to the LSG.

## 2.3 Reasonably foreseeable misuse

The following processing methods are improper:

- Operating the LSG without fully fitted protective devices and protective clothing.
- Use by private users or users without professional instruction and training.

## 2.4 Residual Risk

Even if all safety regulations are observed, the residual risk described below remains when operating the LSG.

- As an entrepreneur/operator, ensure that all persons who work on and with the LSG are aware of the residual risks.

- Follow the instructions that prevent residual risks from causing accidents or damage. During set-up and set-up work, it may be necessary to dismantle on-site protective devices. This results in various residual risks and potential dangers that every operator must be aware of:



*Danger of explosion!*

*Sparks from static electricity can ignite a potentially explosive atmosphere. Life-threatening injuries from flying parts and burns are possible.*

- *Wear anti-static clothing when using the LSG in a potentially explosive atmosphere.*
- *Ground the LSG with the supplied ground wire.*



*Serious injuries possible through incorrect handling*

*Incorrect attachment of the pressure vessel, incorrect filling and incorrect operation of the LSG can cause serious injury to persons.*

- *Only use pressure tanks and spare parts approved for the LSG.*
- *Wear hand protection when using the LSG*
- *Only allow the LSG to be used by persons trained to do so serve qualified personnel.*

## 2.5 Description of Protective Devices

The LSG is designed and constructed in accordance with the standard.

All components of the LSG are designed for maximum pressure.

The LSG may only be operated by trained specialists.

## 2.6 Markings and Signs on LSG

- left intentionally blank -

## 2.7 Operating Personnel

Persons handling the LSG must meet the following requirements:

<i>Employee</i>	<i>Job Duty</i>	<i>Required Qualification</i>
<i>Carrier</i>	Transport from factory to Operation	Qualification of Forwarder for Machines
<i>Commissioning Engineer</i>	Initial commissioning/ Recommissioning	Technicians with an understanding of process engineering systems
<i>Operator</i>	Operation	Specialists with training
<i>Mechanic Maintenance Personnel</i>	On mechanical parts: Troubleshooting Servicing Decommissioning Storage disassembly	Specialist for mechanics (locksmith)
<i>Disposer</i>	Disposal of the Machine	Disposal specialist

## 2.8 Safety Instructions for Operating Personnel

Any person assigned to work on or with the LSG must have read and understood these operating instructions in their entirety.

- Use the LSG only when it is in perfect technical condition and for the intended purpose, with an awareness of safety and the dangers of danger, while observing these operating instructions.

No liability is assumed for damage and accidents caused by non-observance of the operating instructions.

- Eliminate all faults immediately.
- Always keep the operating instructions to hand on the LSG.
- Wear personal protective equipment.
- When handling acids or alkalis, provide an appropriate full-body protective suit (protection classes 1-6).
- Do not wear long hair, loose clothing or jewelry. There is a risk of getting caught, being drawn in or being taken along by moving parts.
- If safety-related changes are made to the LSG, shut down the LSG immediately and secure it.
- Report the incident to the responsible office/person.
- Only reliable, trained and certified personnel of the legally permissible minimum age according to the FLSA may work with the LSG.
- Personnel to be trained, instructed or in the context of general training may only work under the constant supervision of an experienced person.



## 2.9 Safety Instructions for Maintenance Personnel

Adhere to the deadlines for periodic tests/inspections that are prescribed or specified in the operating instructions.

### 2.9.1 Preparation of Maintenance Work

Workshop equipment appropriate to the work is required to carry out maintenance work.

- Only carry out set-up, maintenance, and repair work as well as troubleshooting when the LSG is switched off (without the pressure tank installed).
- If necessary, secure the maintenance area with a red and white safety chain and a warning sign.
- In particular, clean the connections and screw connections before starting maintenance/repair/care to remove dirt or care products.

### 2.9.2 Carrying out the maintenance work

Always tighten loosened screw connections during maintenance and repair work, if necessary, with a torque wrench according to the specifications.

- Ensure the safe and environmentally friendly disposal of operating and auxiliary materials as well as replacement parts as described in Chapter 7.

## 2.10 Notes on Special Types of Dangers

### 2.10.1 Raw Materials, Solvents, Oils, Fats, and other chemical substances

When handling raw materials, solvents, oils, fats and other chemical substances, observe and comply with the applicable regulations and safety data sheets from the manufacturers of these substances regarding storage, handling, use and disposal.

- All work with caustic cleaning agents and substances can cause severe chemical burns and serious eye injuries!
  - Therefore, wear personal protective equipment when working with chemical substances:
    - Safety goggles,
    - protective gloves,
    - protective clothing resistant to the substances,
    - safety shoes.
  - In the event of eye or skin contact, immediately flush the affected area with plenty of water. Suitable facilities (eye wash bottle, washbasin, shower) must be available near the workplace!
- After washing, care for skin that has been contaminated by cleaning agents and disinfectants. Skin damage can be avoided through the preventive use of skin protection products and suitable skin care.
- Select the care product to be used depending on the level of pollution and the individual condition of the skin. Predominantly greasy care products come into question.
  - Do not eat, drink, smoke or store food in rooms where there are chemicals!

#### 2.10.2 Noise

The A-weighted equivalent continuous sound pressure level at the operating workstations during normal operation of the LSG is below 70 dB(A).

- As the operator, equip the operating personnel with the appropriate protective equipment if the local conditions result in a higher sound pressure level at the LSG's location.

### 3. Product Description

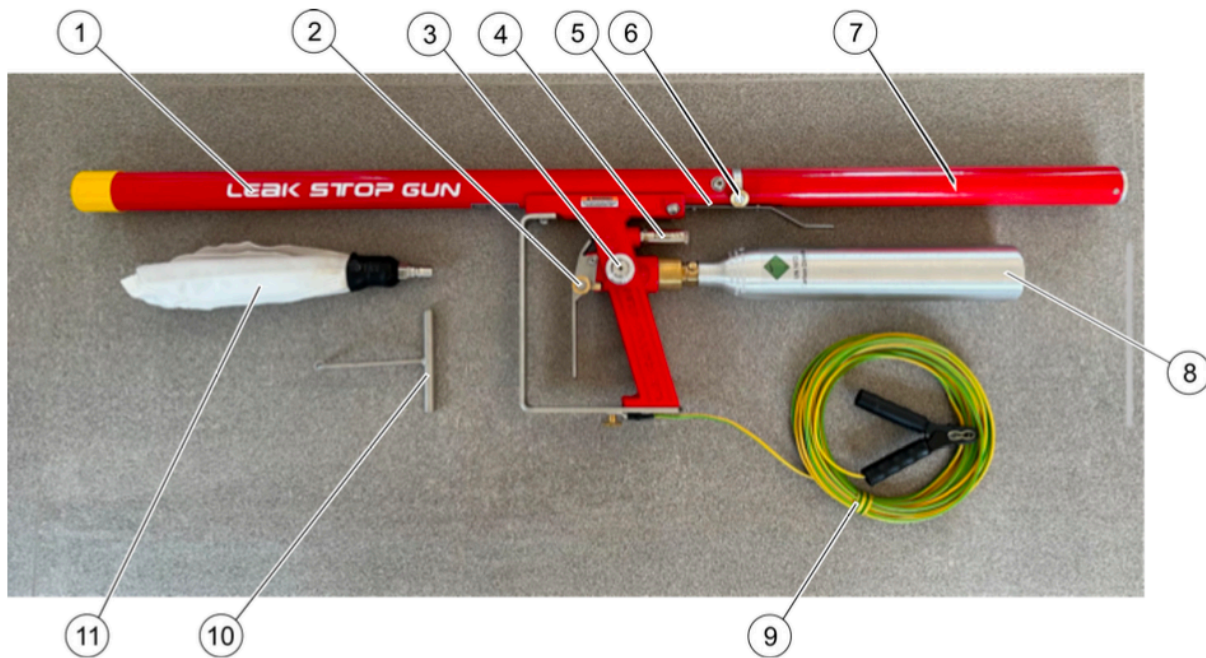

*Pos. Description*

1	Front Run
2	Securing the trigger lever
3	Dump valve with latch - submersible variant
4	Pressure relief valve
5	Locking rear barrel
6	Drainage screw - submersible variant
7	Rear Run
8	CO2 pressurized tank
9	Grounding cable with alligator clip and fixing screw
10	Tool for docking and undocking the sealing balloon
11	Sealing balloon

### 3.1 Functional Description

The function is described in chapter 5.4 Operation.

### 3.2 Assemblies of LSG

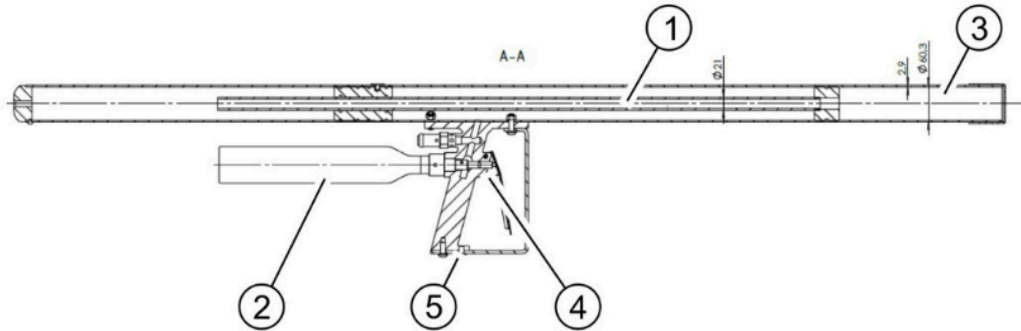

Pos.	Description
1	Piston Rod
2	CO2 pressurized tank
3	Front barrel, space for the leak sealing balloon
4	Securing the trigger lever
5	Grounding Connection

Due to its special requirements, the LSG pressure tank (gas bottle) can only be obtained from the manufacturer LEAK STOP GUN LP. (Length approx. 36 cm, diameter approx. 6 cm, pressure in the bottle approx. 50/130 bar (depending on temperature), content 425g CO2).

The LSG is secured against unintentional operation with a trigger safety device.  
The supplied grounding cable can be attached to the screw without tools on the handle.

3.3 Classification according to the Pressure Equipment Directive

**LSG 400**

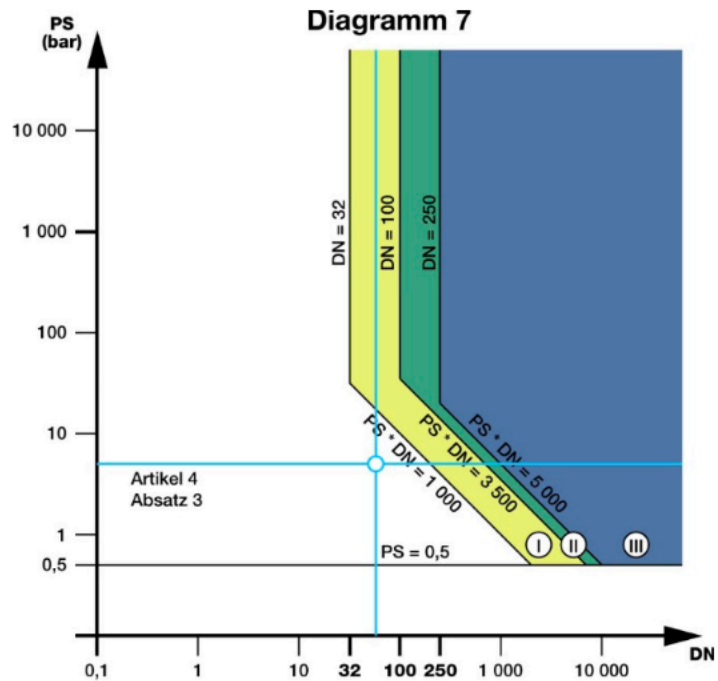

Figure 3 Diagram 7 LSG 400

Object	Pipeline
Medium	Gas or Liquefied Gas
Fluid of the Group	2
Maximum allowable pressure	6 Bar
PS x DN	287
Nominal size DN	57.4 mm
Determination is based on the diagram	7
The facility is omitted in category	good engineering practice Article 4, paragraph 3 DGRL

**LSG 150:**

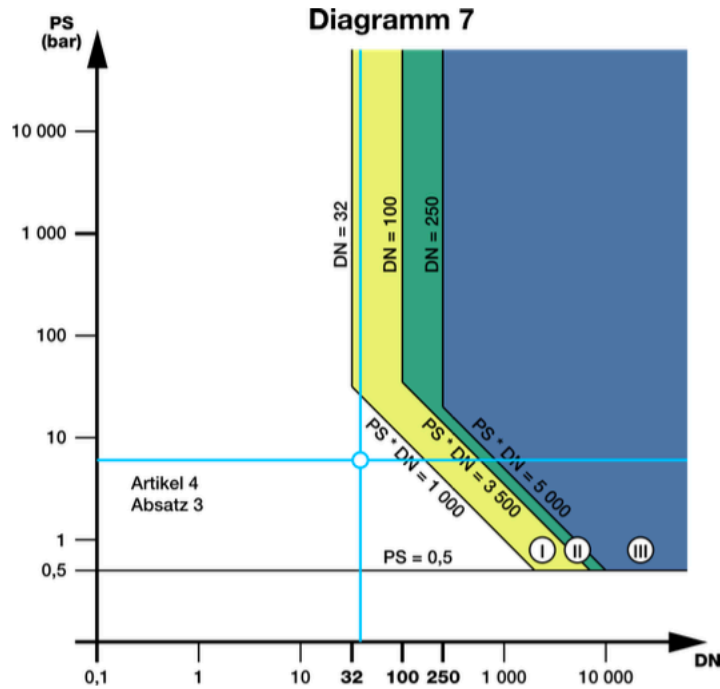

Figure 4 Diagram 7 LSG 150

	Object	Pipeline
Medium		Gas or Liquefied Gas
Fluid of the Group		2
Maximum allowable pressure		6 Bar
PS x DN		230.4
Nominal size DN		38.4 mm
Determination is based on the diagram		7
The facility is omitted in category		good engineering practice Article 4, paragraph 3 DGRL

**Technical Data**

Dimensions LSG 400 (L x W x H)	1.778 x 283 x 92	mm
Dimensions LSG 150 (L x W x H)	1.112 x 270 x 92	mm
Total Weight LSG 400	25.45	Lbs.
Total Weight LSG 150	14.33	Lbs.
Filling Weight of the Pressure Vessel	425	g
Pneumatic, Max. Pressure	6 / 57.3 at 20 °C (68 F)	Bar

## 4. Transportation and Assembly

The LSG was designed, assembled, and tested by LEAK STOP GUN LP.

The weight of the LSG 400 is about 12 kg, the LSG 150 is about 6.5 kg. For this reason, the LSG can be handled by one person without any tools.

The LSG is shipped professionally by LEAK STOP GUN LP.

- After receiving the LSG, check that the scope of delivery is complete using the enclosed packing list.
- Complain about any missing parts with precise information according to the package list.
- Only transport the LSG with the trigger safety closed or with the gas cylinder unscrewed.
- Thoroughly clean the LSG before sending the LSG back to the manufacturer LEAK STOP GUN LP.

## 5. Operation

Every person involved in the operation, maintenance, and repair of the LSG must have read and understood this chapter "5 Operation" thoroughly.

### 5.1 Safe Operation

Work on the LSG may only be carried out by trained and/or instructed personnel. Improper use can result in danger to life and limb.

The LSG may only be operated by authorized, technically qualified persons.

A suitably qualified person can, based on their technical training, knowledge and professional experience as well as knowledge of the accident prevention and occupational health and safety regulations, assess and carry out the work assigned to them and recognize possible dangers if they also meet the necessary personal requirements for the activity, e.g. can work independently.

- Only use the LSG for the purpose specified by the manufacturer or customary.
- Only ever operate the LSG when it is in perfect technical condition to avoid accidents.
- Do not use any third-party parts on the LSG, otherwise compliance with the required level of safety cannot be guaranteed.
- Refrain from working in any way that compromises the safety of the LSG.

- Immediately report any changes to the LSG (which affect safety) to the responsible supervisor.
- Shut down the LSG immediately in the event of a malfunction affecting safety. Do not put the LSG back into operation until the fault has been rectified.
- Do not dismantle or manipulate any safety devices. Do not disable safety devices.

As the operator, ensure that the functional test of the safety devices on the LSG is carried out by trained personnel both before the first and before each new start-up.

As the operator, make the required personal protective equipment (PPE) available to the operating personnel, especially with the following:

- Antistatic clothing for using the LSG in a potentially explosive atmosphere.
- Gloves, as the LSG gets cold during operation.

Make sure that the PPE is always used.

## 5.2 Controls

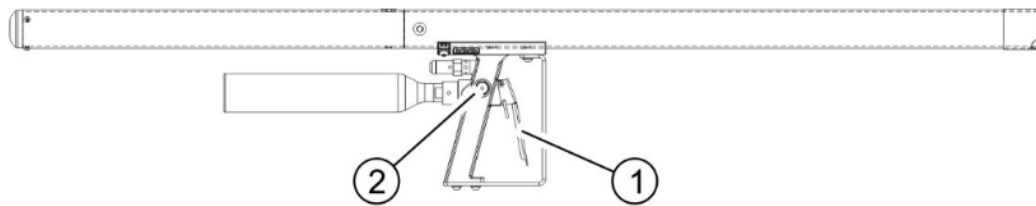

Figure 5 LSG Controls

The operator releases the gas with the trigger (1), which expels the sealing ball and then inflates it.

Release of pressure (2):

- By turning the screw to the right after use, a pressure reduction in the sealing ball is triggered and the LSG can be removed from the place of use.
- The drain valve is locked by turning the screw to the left. This means that no liquid can penetrate - up to 20 m water depth.

## 5.3 Installation

Before commissioning the system, check all aggregates and important functions with the following points:

	Examination	Task
Conserved Areas		Depressive and clean



Visual inspection of the LSG

Levels

Leak Test

Check for correct assembly. Check for damage and remove foreign objects.

Check

Check the pressure tank connection for leaks.

## 5.4 Operation

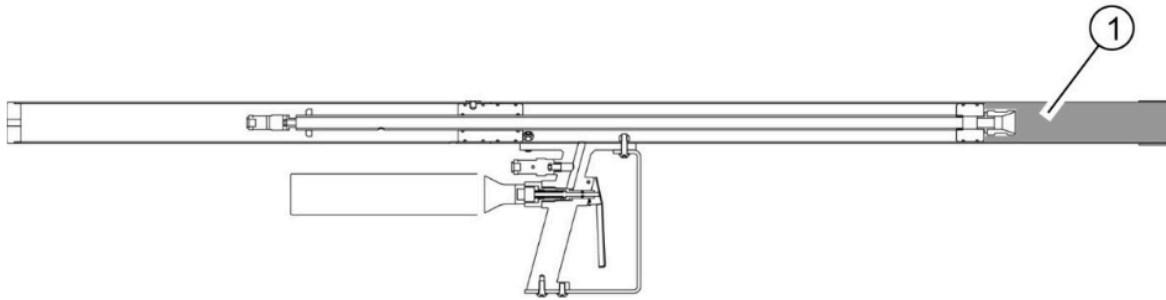

Figure 6 LSG at rest.



*Danger of explosion!*

*Sparks from static electricity can ignite a potentially explosive atmosphere. Life-threatening injuries from flying parts and burns are possible.*

- Wear anti-static clothing when using the LSG in a potentially explosive atmosphere.
- Ground the LSG with the supplied ground wire.

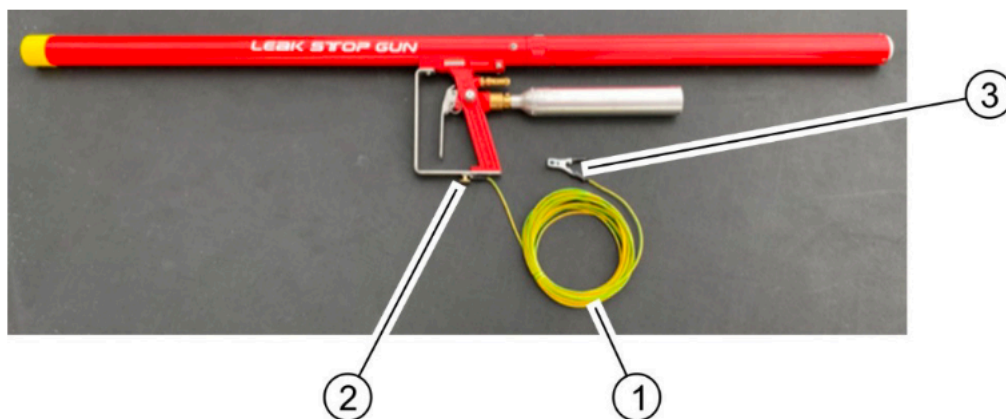

Figure 7 Ground wire connection

When using the LSG in a potentially explosive atmosphere, ground it as follows:

- Attach the supplied ground wire (1) to the underside of the handle with the screw (2).

- Connect the grounding cable with the crocodile clip (3) to a conductive metallic object. This object - e.g. water pipe, heating - must be connected to the earth potential.

## **! WARNING**

*Beware of cold burns!*

*If you pull the trigger several times, the trigger can ice up and you can get cold burns on your hands.*

- Wear hand protection when using the LSG

### **Step 1**

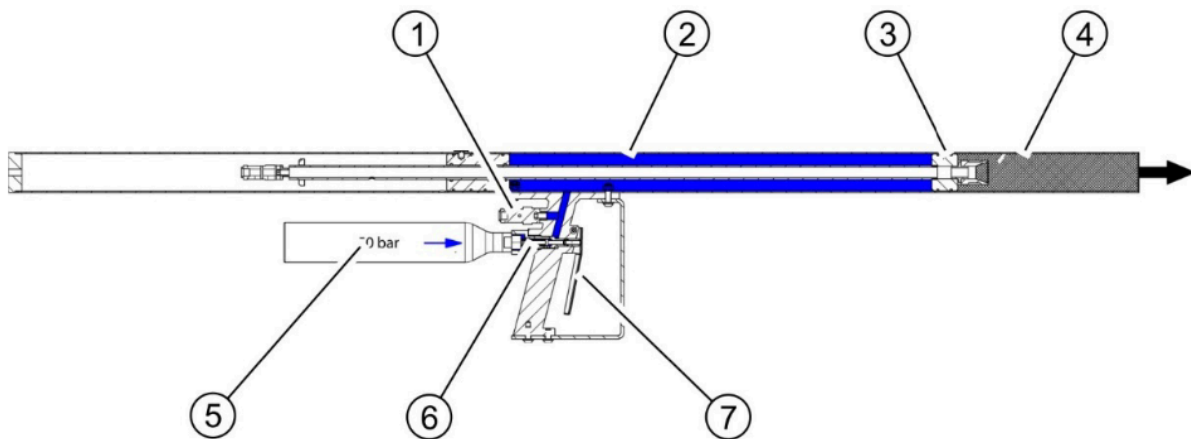

Figure 8 Step 1

Pos.	Task
1	Pressure relief valve - piston rod
2	pressure 6 bars
3	Pistons
4	Sealing Balloon
5	CO2 pressurized tank
6	Control Valve
7	Trigger
8	Pressure relief valve - sealing balloon

Position the LSG.

- Loosen the locking screw on the trigger (7).

- Actuate the trigger (7) and thus also the control valve (6). CO2 flows from the reservoir (5) through the handle into the tube.

When sufficient pressure - 6 bar - has built up in the barrel (2), the piston (3) is pushed, which in turn drives the sealing ball (4) out of the barrel. The protective cap is pushed off. The pressure (6 bar) in the pipe is regulated by the pressure relief valve (1).

## **Step 2**

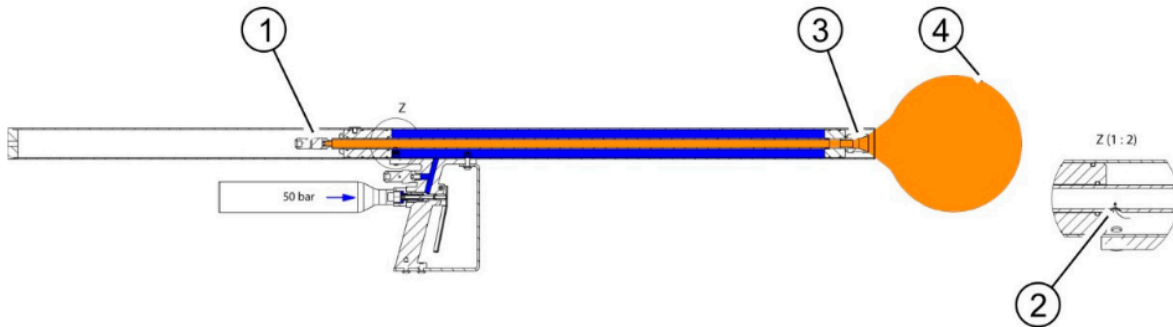

Figure 9 Step 2

The sealing balloon (4) is inflated to 1.8 - 2.0 bar (3) and can thus seal the existing leak. The piston together with the tube extends until the bore (2) is exposed. The pressure thus flows into the pipe. The pressure is regulated with the pressure relief valve (1).

If the balloon must remain in the leak, you have the option of removing the LSG from the balloon.



Figure 10 Step 2a

- To release the balloon, insert the tip of the release lever (5) into the notch provided on the front barrel of the LSG and pull the inserted lever in the direction of the arrow.



Figure 11 Step 2b

- Pull the LSG off the balloon in the direction of the arrow.

### **Step 3**

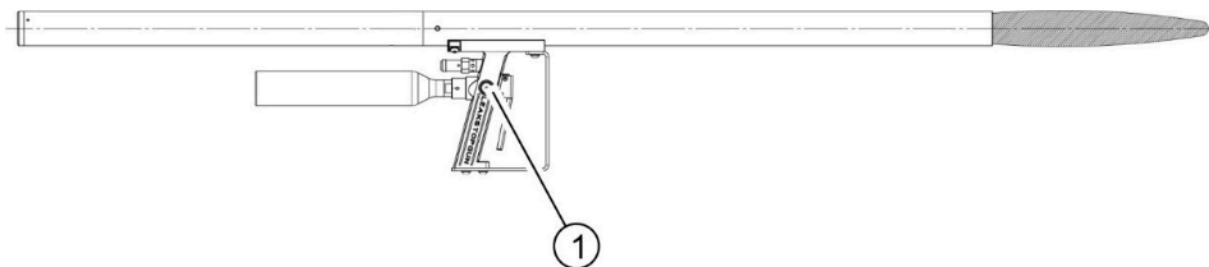

Figure 12 Step 3

Reduce the pressure with the help of the drain valve (1).

By opening/closing the deflation valve and the trigger, you can optimize the sealing surface of the sealing balloon.

If you only open the release valve - turn the release valve retainer to the right - the sealing balloon will collapse, and the LSG can thus be removed from the leak.

#### **Step 4**

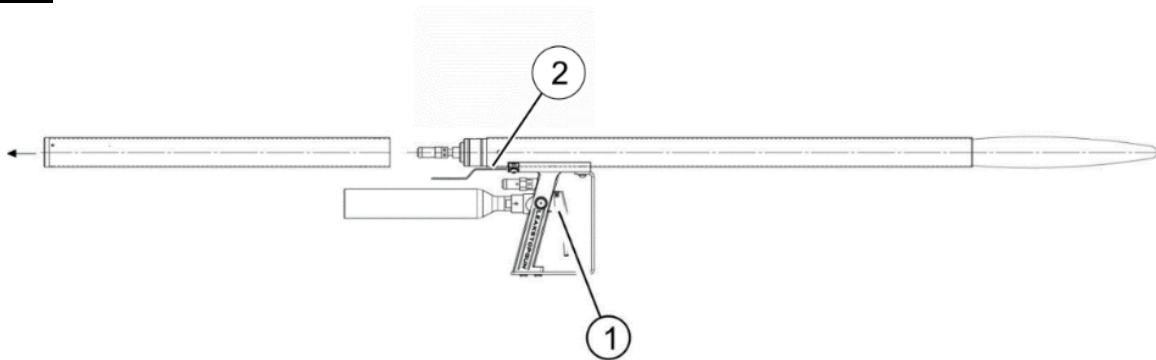
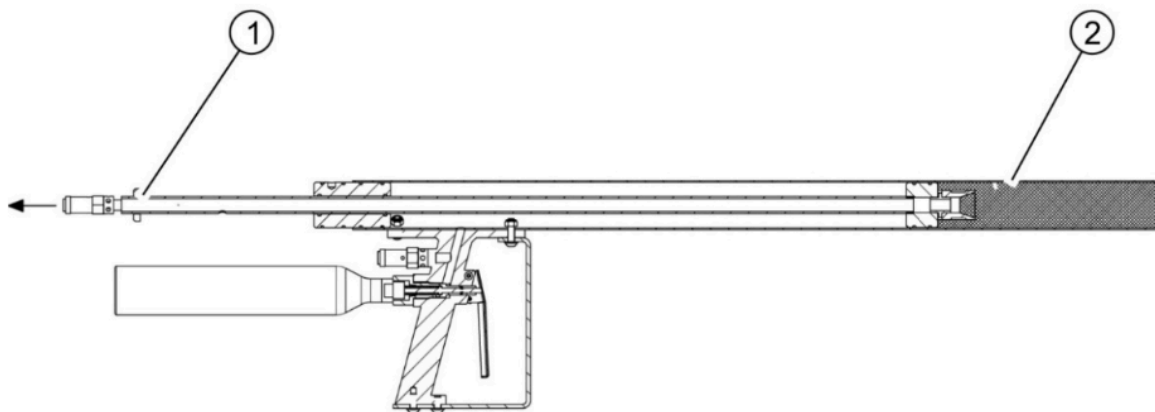

*Figure 13 Step 4*

After you have removed the LSG from the leak and deflated the sealing balloon:

- Secure the trigger by tightening the locking screw (1).
- Press the spring steel bracket (2) down.

#### **Step 5**

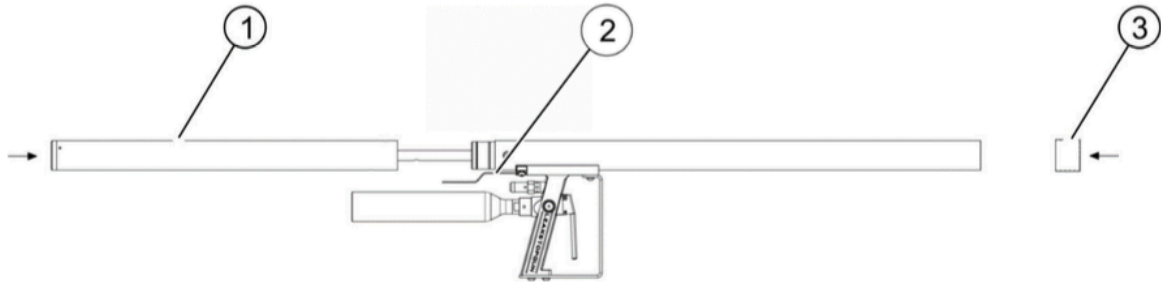

*Figure 14 Step 5*

Pull out the piston rod (1).

The sealing balloon is drawn into the barrel (2).

**Step 6**



Slide on the rear tube (1).

- Check that the spring steel clip (2) has snapped back into the rear tube.

**Step 7**

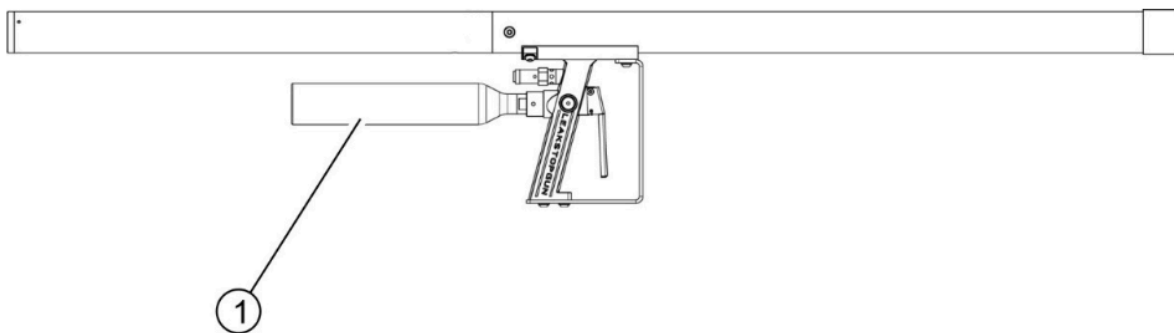

*Figure 16 Step 7*

Replace the CO2 pressure tank (1) after each use.

5.5 Errors

- In the event of a fault, contact the manufacturer Leak Stop Gun LP.

## 6. Maintenance

The maintenance chapter is divided into the areas of care, maintenance and repair. This should make it easier for you to plan the necessary maintenance work.

The instructions described in this chapter are to be understood as minimum requirements. Depending on operating conditions, further instructions may be required to keep the LSG in optimal condition. The specified time intervals refer to single-shift operation. Maintenance instructions for specific assemblies can be found in the relevant supplier documentation in Chapter 8.

The maintenance and repair work described in this chapter may only be carried out by the operator's specially trained repair personnel.

Maintenance and repair work in special fields, e.g., pneumatics, may only be carried out by specialists who have been trained in the respective field.

For repairs and spare parts orders, we refer to the drawings and parts lists that can be provided by LEAK STOP GUN LP.

Liability for defects resulting from the following causes is excluded: poor maintenance, use of non-original spare parts, modification without the written consent of the seller, poorly executed repairs by the buyer or normal wear and tear.

Any spare parts used must meet the technical requirements specified by LEAK STOP GUN LP. This is always guaranteed with original spare parts.

- With regard to the storage, handling, use and disposal of gases, fats, oils and other chemical substances, read the manufacturer's applicable regulations and safety data sheets as well as the instructions from the operator's applicable operating instructions. Strictly comply with these regulations and instructions.
- Ensure that operating materials and replacement parts are disposed of safely and in an environmentally friendly manner.
- Observe the safety instructions on the following pages.

## 6.1 Care/Cleaning

Clean the LSG after each use.

Maintenance of the LSG is essentially limited to once a week.

Cleaning all surfaces from dust and other deposits.

- Sweep or wipe the LSG only. We do not recommend using it on sensitive surfaces.

# NOTICE

Improper cleaning of the LSG can lead to malfunctions and damage.

- *Do not choose aggressive cleaning agents that attack metal and plastic surfaces and hose connections.*

- *Never clean sensitive components with coarse brushes and strong mechanical pressure. Use lint-free cleaning cloths.*

- *Never clean the LSG with a water jet or high-pressure cleaner.*

- *All aqueous industrial cleaners can be used without restrictions.*

*Appropriate care helps to keep the LSG in a functional condition over the long term.*

- *Thoroughly clean the LSG at least once a week.*

- *Do not use metal objects such as scrapers or screwdrivers to clean bare machine parts such as piston rods or guides.*

- *Do not use aggressive cleaning agents or solvents (damage seals), or emery paper for cleaning.*



# NOTICE

*Do not clean the LSG with compressed air. As a result, dust and/or dirt particles can get to the seals and sealing surfaces and damage them.*

*Observe the information from the safety data sheets as well as those of the respective hazardous substances and the consequences thereof.*

## 6.2 Maintenance

### 6.2.1 General Maintenance Instructions

A high availability of the LSG is positively influenced by adhering to the suggested care and maintenance intervals.

- Check the LSG regularly and inform the person responsible if repair and maintenance work is necessary.



*Beware of bodily harm*

*In the event of misconduct, there is a risk of hand injuries due to uncontrolled movements of the LSG.*

- *Only allow repair and maintenance work to be carried out by trained and authorized specialist personnel in compliance with the safety instructions and the applicable accident prevention regulations.*
- *Only carry out set-up, maintenance and repair work as well as troubleshooting when the system is depressurized – remove the pressure tank.*

### 6.2.2 Preparation of Repair and Maintenance Work

When working, only use the correct tools and only replace worn parts, such as screws or nuts, with original spare parts.

- Carefully mark the components before dismantling.



*Injuries due to insufficient visibility possible*

*If visibility is poor, you can only insufficiently recognize possible danger spots.*

- *Only carry out repair and maintenance work on the LSG when there is sufficient lighting.*
- *Before any work on the LSG is done, remove the pressure vessels.*

### 6.3 Maintenance Schedule

Carry out the maintenance work at the intervals specified below. The times given correspond to single-shift operation. Adjust the time specifications accordingly for multi-shift operation. This work ensures that the LSG functions consistently and without problems.

The maintenance plan shows which work must be carried out at the designated points on a weekly, monthly or semi-annual basis.

<i>Interval</i>	<i>Work to be done</i>	<i>Responsible staff</i>
<i>Daily</i>	Check safety and protective devices.	Operating Staff
<i>Monthly</i>	Clean all system components. Check components for wear.	Maintenance Staff
<i>Semi-Annual</i>	Check all protective devices, it must be checked individually: -Condition -Tight Fit	Maintenance Staff
<i>Annual</i>	Check the function of the entire system.	Service Staff
<i>Every 5 Years</i>	Strength Testing External Exam	Qualified person according to PED

### 6.3.1 Changing the Pressure Tank



*Hand injuries possible!*

*A pressurized tank can injure your hands through uncontrolled movements.*

- *Do not change the pressure tank until the pressure tank is empty and no longer pressurized.*
- *Carefully unscrew the empty pressure tank.*
- *Clean the threads on the new pressure vessel and LSG.*
- *Carefully screw the new pressure vessel onto the LSG.*
- *Make sure that the new pressure tank is completely tightly connected to the LSG.*

### 6.4 Repair

Repair work on the LSG may only be carried out by the operator's trained and authorized specialists. The instructions in this chapter are limited to important general information and notes that must be followed during repair work.

The following applies to all attachment and disassembly work:

- Mark parts according to how they belong together.
- Mark the installation position and location and record this data.
- After reassembly, tighten all mechanical connections again.

## 7. Disposal

### 7.1 Environmental Protection



*Environmental pollution from substances hazardous to water*

*These substances can pollute the soil and groundwater or get into the sewage system.*

- *For all work on and with the LSG, comply with the legal obligations regarding waste avoidance and proper recycling/disposal.*

- *Follow local government regulations when disposing of consumables or replacements during maintenance or when decommissioning the LSG.*
- *Please note that particularly during installation, repair and maintenance work, substances that are hazardous to water, such as lubricating grease and oil, emulsions and liquids containing petrol, must not pollute the floor or get into the sewage system.*
- *Please note that these substances must be stored, transported, collected and disposed of in suitable containers.*

## 7.2 Oil and Waste Containing Oil, Lubricating Greases

Oil and waste containing oil as well as lubricating greases represent a high-risk potential for the environment. Therefore, their disposal is carried out by special companies.

- Take this waste to the company's internal disposal, which will forward it to specialist companies.

## 7.3 Plastics

- Sort the plastics used/processed as far as possible.
- Dispose of plastics in compliance with legal requirements.

## 7.4 Metals

- Separate the metals used/processed as far as possible.
- Have metals disposed of by an authorized company.

## 7.5 Scrapping

- Check which materials can be recycled and then arrange for recycling or reach out to Leak Stop Gun LP.

## Appendix

- Declaration of Conformity
- assembly drawings
- Parts list with spare parts recommendation/identification – Supplier documentation

### A.1 Declaration of Conformity

Copy of the signed declaration of conformity

### A.2 Assembly Drawings

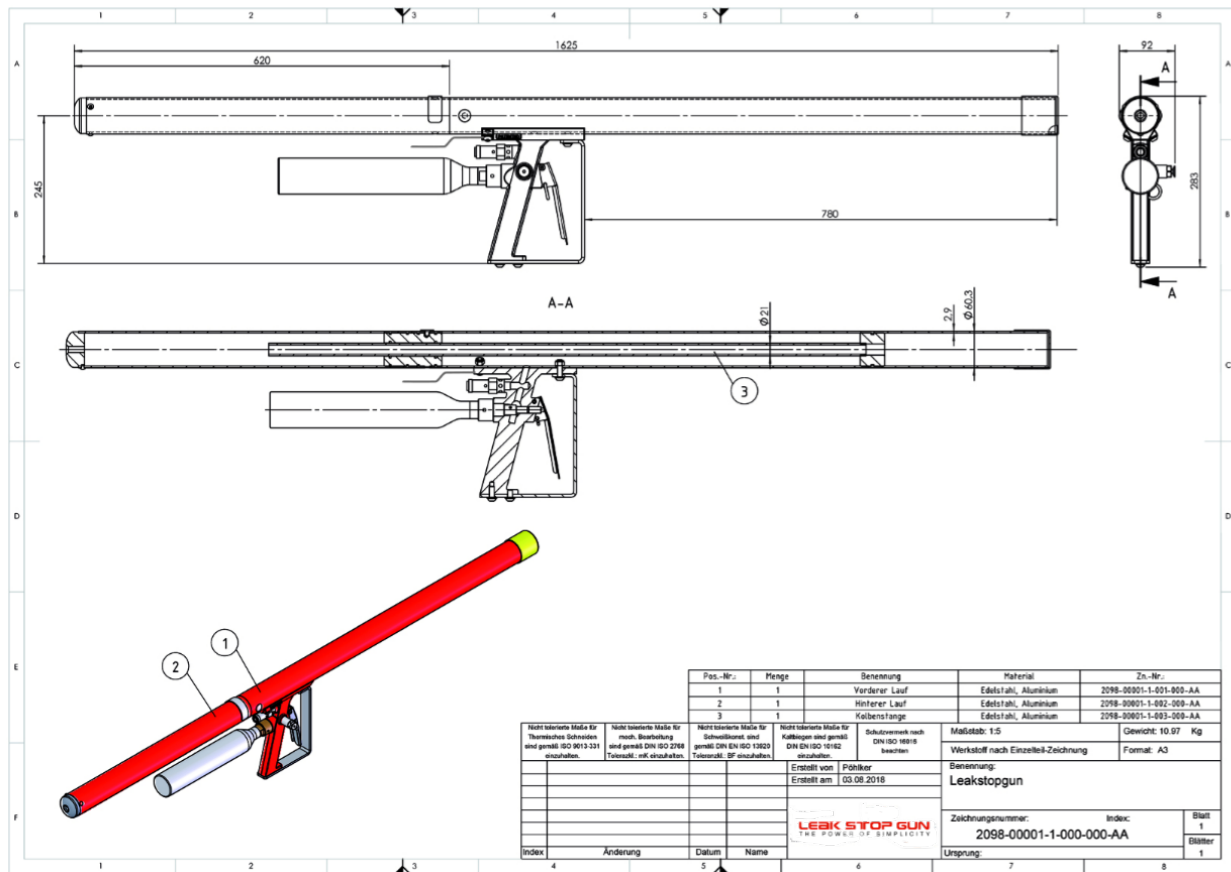

### A.3 Parts list with spare parts recommendation/identification

- Can be requested from the manufacturer at any time -